

*Gig***BAR** BRIDGE **BEAM** ILS

User Manual

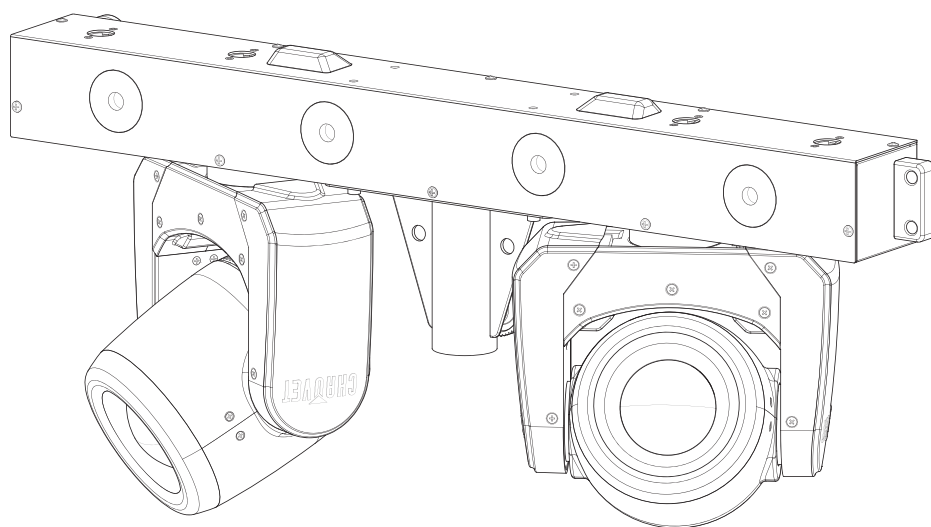

Edition Notes

The GigBAR Bridge Beam ILS User Manual includes a description, safety precautions, installation, programming, operation, and maintenance instructions for the GigBAR Bridge Beam ILS as of the release date of this edition.

Trademarks

Chauvet, Chauvet DJ, the Chauvet logo, and PRODUCTLINE are registered trademarks or trademarks of Chauvet & Sons, LLC (d/b/a Chauvet and Chauvet Lighting) in the United States and other countries. Other company and product names and logos referred to herein may be trademarks of their respective companies.

Copyright Notice

The works of authorship contained in this manual, including, but not limited to, all designs, text, and images are owned by Chauvet.

© Copyright 2026 Chauvet & Sons, LLC. All rights reserved.

Electronically published by Chauvet in the United States of America.

Manual Use

Chauvet authorizes its customers to download and print this manual for professional information purposes only. Chauvet expressly prohibits the usage, copy, storage, distribution, modification, or printing of this manual or its content for any other purpose without written consent from Chauvet.

Document Printing

For best results, print this document in color, on letter size paper (8.5 x 11 in), double-sided. If using A4 paper (210 x 297 mm), configure the printer to scale the content accordingly.

Intended Audience

Any person installing, operating, and/or maintaining this product should completely read through the guide that shipped with the product, as well as this manual, before installing, operating, or maintaining this product.

Disclaimer

Chauvet believes that the information contained in this manual is accurate in all respects. However, Chauvet assumes no responsibility and specifically disclaims any and all liability to any party for any loss, damage, or disruption caused by any errors or omissions in this document, whether such errors or omissions result from negligence, accident, or any other cause. Chauvet reserves the right to revise the content of this document without any obligation to notify any person or company of such revision; however, Chauvet has no obligation to make, and does not commit to make, any such revisions.

Document Revision

Go to www.chauvetdj.com for the latest version.

Revision	Date	Description
1	01/2026	Initial release.

TABLE OF CONTENTS

- 1. Before You Begin** 1
 - What Is Included 1
 - Unpacking Instructions 1
 - Claims..... 1
 - Text Conventions..... 1
 - Symbols..... 1
 - Safety Notes 2
 - FCC Statement of Compliance 3
 - RF Exposure Warning for North America and Australia 3
- 2. Introduction** 4
 - Product Overview 4
 - Product Dimensions 5
- 3. Setup** 6
 - AC Power 6
 - AC Plug..... 6
 - Fuse Replacement..... 6
 - Power Linking 7
 - Mounting..... 8
 - Orientation 8
 - Rigging..... 8
 - Mounting Diagram with 2 Clamps 8
 - Mounting Diagram with 1 Clamp 9
 - Alignment Tab, Slot, and Pins 9
 - Mounting Diagram with Tripod 10
 - Inverting the Tripod Mount..... 11
- 4. Operation** 12
 - Control Panel Operation 12
 - Menu Map..... 12
 - DMX Configuration 15
 - DMX Personalities 15
 - Starting Address 15
 - D-Fi USB Connectivity..... 16
 - D-Fi USB Compatibility 16
 - D-Fi USB Configuration 16
 - DMX Channel Assignments and Values..... 17
 - Zones for DMX Control 17
 - DMX Charts 17
 - 03CH 17
 - 24CH 17
 - 60Ch..... 18
 - Standalone Configuration 21
 - Mixed Effect Modes 21
 - Automatic Mixed Effect..... 21
 - Sound-Active Mixed Effect 21

Program Selection	21
Program Mode.....	21
Program Speed	21
Sound Sensitivity.....	21
Program Beam Movement	22
Program Beam Speed.....	22
Dimmer.....	22
Strobe.....	22
Program Time.....	22
Sound Lost	22
Manual Mode	22
Settings Configuration	23
D-Fi Settings	23
D-Fi Mode.....	23
D-Fi Channel	23
Pan Reverse.....	23
Tilt Reverse	23
Pan Range	23
Tilt Range	24
DMX Loss.....	24
Back Light Timer	24
Screen Reverse.....	24
Totem Mode	24
Factory Reset.....	24
Firmware Update.....	24
System Information.....	25
Wireless Footswitch Configuration	25
Footswitch Overview.....	25
Footswitch Operation.....	25
Footswitch Binding.....	25
Footswitch Battery	26
Battery Replacement.....	26
RFC Remote Control	26
RFC Control Mode.....	26
RFC Remote Binding.....	26
RFC Remote Control Operation	27
Wired Master/Slave Mode	28
D-Fi Master/Slave Mode	28
5. Maintenance.....	29
Product Maintenance.....	29
6. Technical Specifications	30
Contact Us	31
Warranty & Returns	31

1. Before You Begin

What Is Included

- GigBAR Bridge Beam ILS
- Power cable
- Carry bag
- 2 hanging brackets
- RF remote
- Quick Reference Guide

Unpacking Instructions

Carefully unpack the product immediately and check the container to make sure all the parts are in the package and are in good condition.

Claims





If the box or the contents (the product and included accessories) appear damaged from shipping, or show signs of mishandling, notify the carrier immediately, not Chauvet. Failure to report damage to the carrier immediately may invalidate a claim. In addition, keep the box and contents for inspection.

For other issues, such as missing components or parts, damage not related to shipping, or concealed damage, file a claim with Chauvet within 7 days of delivery.

Text Conventions

Convention	Meaning
1–512	A range of values
50/60	A set of values of which only one can be chosen
Settings	A menu option not to be modified
<ENTER>	A key to be pressed on the product’s control panel
ON	A value to be entered or selected

Symbols

Symbol	Meaning
	Electrical warning. Not following these instructions may cause electrical damage to the product, accessories, or the user.
	Critical installation, configuration, or operation information. Not following these instructions may make the product not work, cause damage to the product, or cause harm to the operator.
	Important installation or configuration information. The product may not function correctly if this information is not used.
	Useful information.

Safety Notes

These Safety Notes include important information about installation, use, and maintenance of the GigBAR Bridge Beam ILS.



- **ALWAYS:**

- ◆ Connect to a grounded circuit.
- ◆ Connect to operating voltages as specified on the product's spec sticker.
- ◆ Disconnect from power before replacing the fuse.
- ◆ Disconnect from its power source during periods of inactivity.
- ◆ Use a safety cable when suspending overhead.
- ◆ Heed all restrictions and warnings on the spec sticker.
- ◆ Mount in a location with at least 20 in (50 cm) of ventilation.
- ◆ Replace the fuse with the same type and rating.
- ◆ Use a clamp with a captive bolt when a single hanging bracket is used.

- In the event of a serious operating problem, stop using immediately.

- **DO NOT:**

- ◆ Open this product or attempt any repairs. It contains no user-serviceable parts.
- ◆ Look at the light source when the product is on.
- ◆ Use if the power cable is crimped or damaged.
- ◆ Disconnect by pulling on the power cable.
- ◆ Allow flammable materials close to the product when it is operating.
- ◆ Touch the housing when it is on.
- ◆ Block any ventilation holes/slots in the housing.
- ◆ Connect to a dimmer or rheostat.
- ◆ Carry the product by its power cable.
- ◆ Operate in temperatures higher than 104°F (40°C).
- ◆ Expose to environments that exceed the Ingress Protection (IP) rating.
- ◆ Expose to rain or moisture.
- ◆ Use outdoors.
- ◆ Submerge.



Keep this User Manual for future use. If the product is sold to someone else, be sure that they also receive this document.

FCC Statement of Compliance

This device complies with Part 15 Part B of the FCC rules. Operation is subject to the following two conditions:

1. This device may not cause harmful interference, and
2. This device must accept any interference received, including interference that may cause undesired operation.

This equipment has been tested and found to comply with the limits for a Class B digital device, pursuant to Part 15 of the FCC Rules. These limits are designed to provide reasonable protection against harmful interference in a residential installation. This equipment generates uses and can radiate radio frequency energy and, if not installed and used in accordance with the instructions, may cause harmful interference to radio communications. However, there is no guarantee that interference will not occur in a particular installation. If this equipment does cause harmful interference to radio or television reception, which can be determined by turning the equipment off and on, the user is encouraged to try to correct the interference by one or more of the following measures:

- Reorient or relocate the receiving antenna.
- Increase the separation between the equipment and receiver.
- Connect the equipment into an outlet on a circuit different from that to which the receiver is connected.
- Consult the dealer or an experienced radio/TV technician for help.

Any changes or modifications not expressly approved by the party responsible for compliance could void the user's authority to operate the equipment.

RF Exposure Warning for North America and Australia

Warning! This equipment complies with FCC radiation exposure limits set forth for an uncontrolled environment. This equipment should be installed and operated with a minimum distance of 20 cm between the radiator and the user. This transmitter must not be co-located or operating in conjunction with any other antenna or transmitter.

2. Introduction

Product Overview

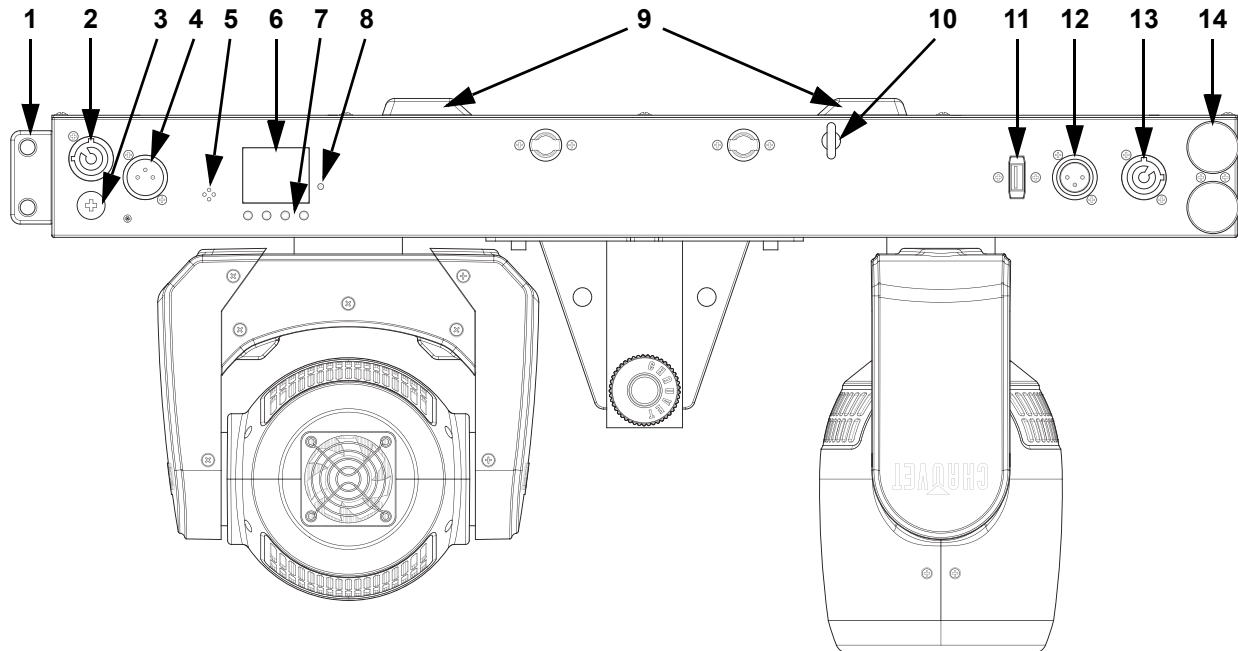

#	Name	#	Name
1	Alignment tab	8	LED indicator
2	Power in	9	Antennae
3	Fuse holder	10	Safety loop
4	DMX in	11	USB type A port
5	Microphone	12	DMX out
6	Menu display	13	Power out
7	Menu buttons	14	Alignment slot pins



WARNING! DO NOT use the USB type A port for any purpose other than updating the firmware. Doing so may cause damage to the product.

Product Dimensions

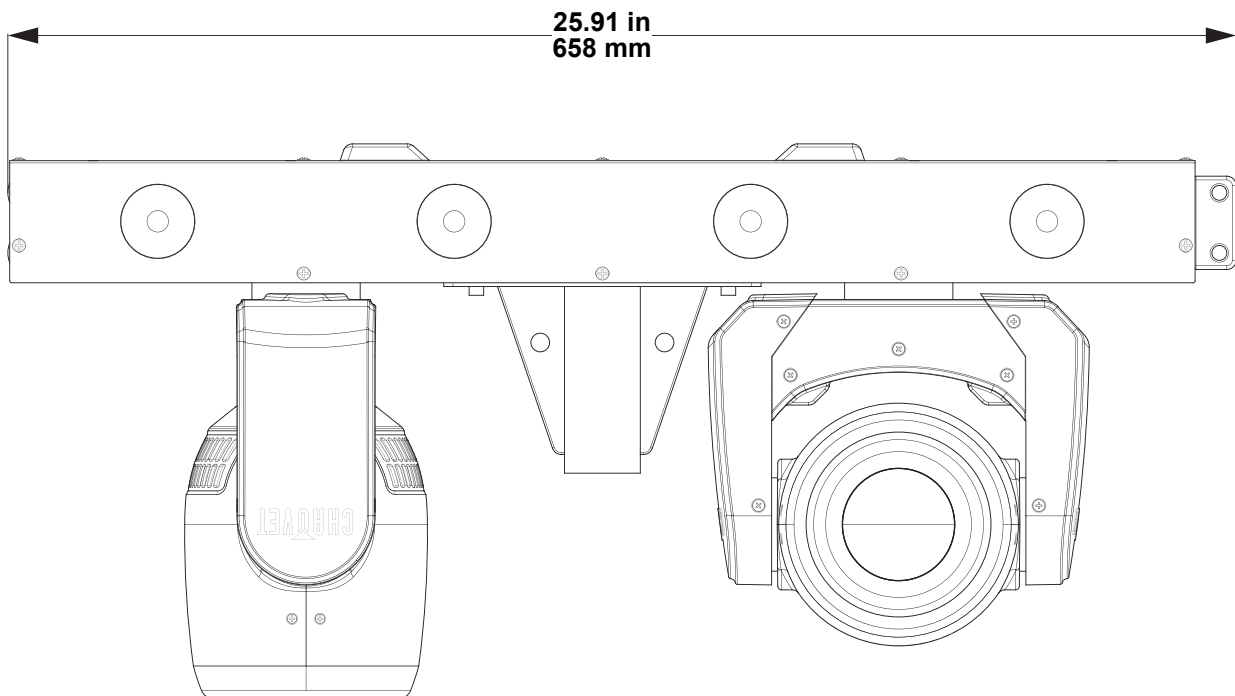
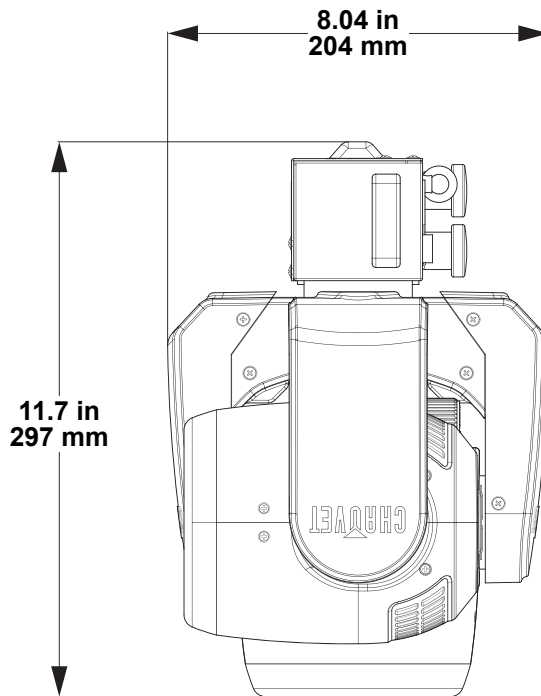

3. Setup

AC Power

The GigBAR Bridge Beam ILS has an auto-ranging power supply and it can work with an input voltage range of 100 to 240 VAC, 50/60 Hz.

To determine the product's power requirements (circuit breaker, power outlet, and wiring), use the current value listed on the label affixed to the product's back panel, or refer to the product's specifications chart. The listed current rating indicates the product's average current draw under normal conditions.



- **Always connect the product to a protected circuit (a circuit breaker or fuse). Make sure the product has an appropriate electrical ground to avoid the risk of electrocution or fire.**
- **To eliminate unnecessary wear and improve its lifespan, during periods of non-use completely disconnect the product from power via breaker or by unplugging it.**



Never connect the product to a rheostat (variable resistor) or dimmer circuit, even if the rheostat or dimmer channel serves only as a 0 to 100% switch.

AC Plug

This product can be connected to a dimmer or rheostat, by plugging in to a standard outlet controlled by a dimmer or rheostat, or by splicing the power cable and connecting to the included track adapter.

Connection	Wire (U.S.)	Wire (Europe)	Screw Color
AC Live	Black	Brown	Yellow/Brass
AC Neutral	White	Blue	Silver
AC Ground	Green/Yellow	Green/Yellow	Green/Silver



Splicing to a commercial track lighting or dimmer setup should be completed by a licensed professional.

Fuse Replacement

1. Disconnect the product from power.
2. Using a Phillips-head screwdriver, unscrew the fuse holder and pull it straight out.
3. Remove the blown fuse from the holder and replace with a fuse of the exact same type and rating.
4. Re-insert the fuse holder and reconnect power.



Disconnect the product from the power outlet before replacing the fuse.



Always replace a blown fuse with one of the same type and rating.

Power Linking

This product provides power linking via the outlet located in the back of the product. See the diagram below for further explanation.

Power Linking Diagram

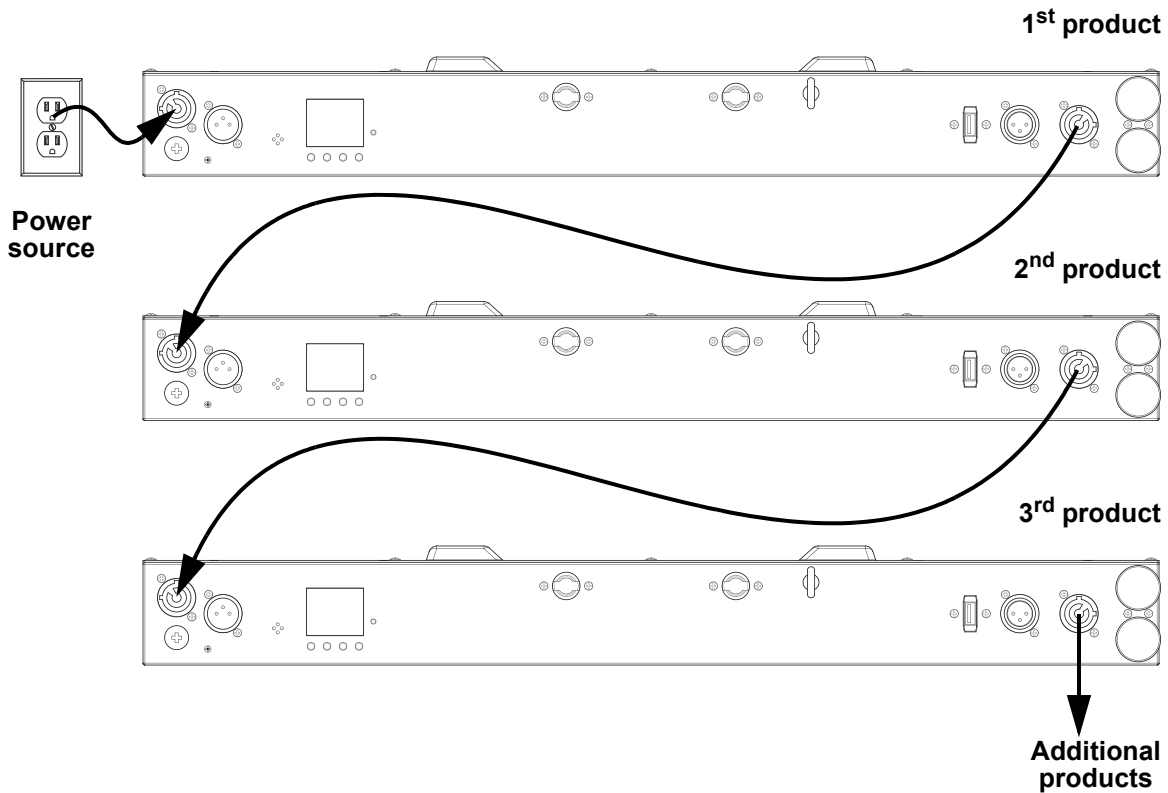

It is possible to link up to 9 GigBAR Bridge Beam ILS products on 120 VAC or up to 18 products on 230 VAC.



The power linking diagram shown above corresponds to the North American version of the product ONLY! If using the product in other markets, consult with the local Chauvet distributor as power linking connectors and requirements may differ by country or region.

Mounting

Before mounting the product, read and follow the safety recommendations indicated in the [Safety Notes](#).

Orientation

The GigBAR Bridge Beam ILS may be mounted in any position; however, make sure adequate ventilation is provided around the product.

Rigging

- Before deciding on a location for the product, always make sure there is easy access to the product for maintenance and programming.
- Make sure that the structure and attachment points can support the weight before hanging the product (see the [Technical Specifications](#) section for weight information).
- When mounting the product overhead, always use a safety cable. Mount the product securely to a rigging point, such as an elevated platform or a truss.
- When rigging the product onto a truss, use a mounting clamp of appropriate weight capacity. The bracket has a 13-mm hole, which is appropriate for this purpose.
- Only loosen or tighten the tripod knobs manually. Using tools could damage the knobs.
- When power linking multiple products, mount the products close enough for power linking cables to reach.
- When mounting the product on the floor, make sure that the product and cables are away from people and vehicles.

Mounting Diagram with 2 Clamps

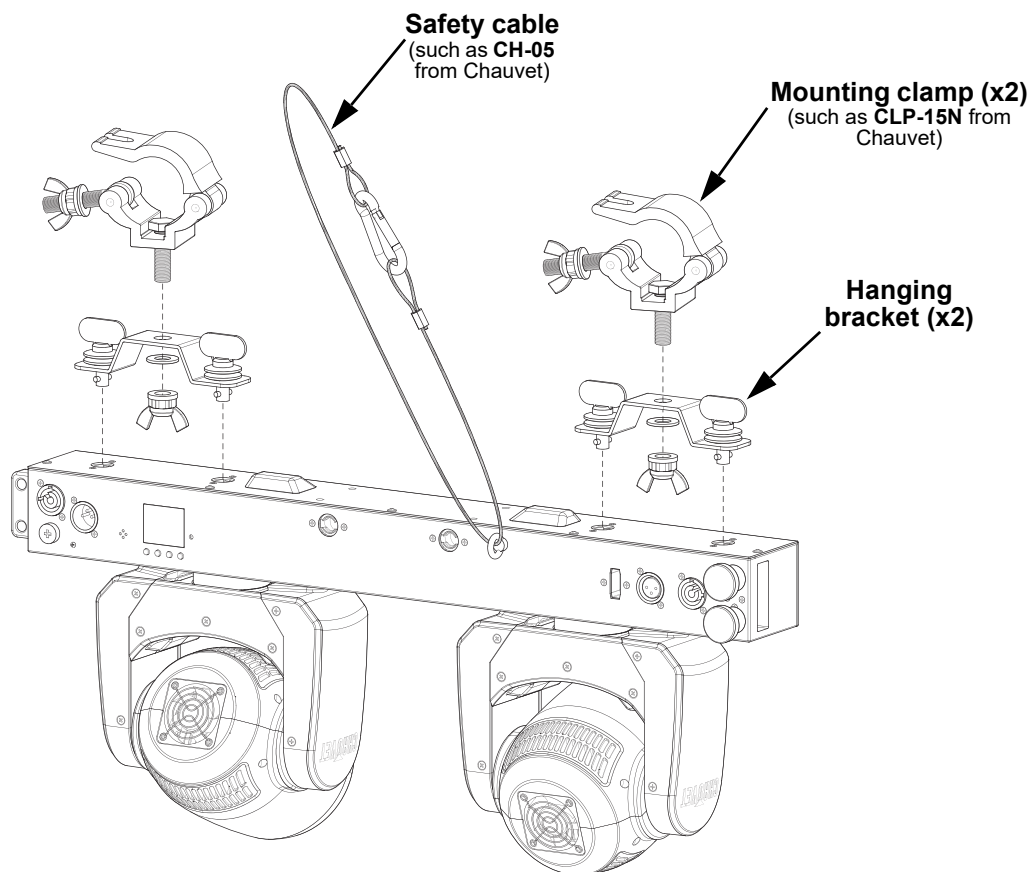

Mounting Diagram with 1 Clamp

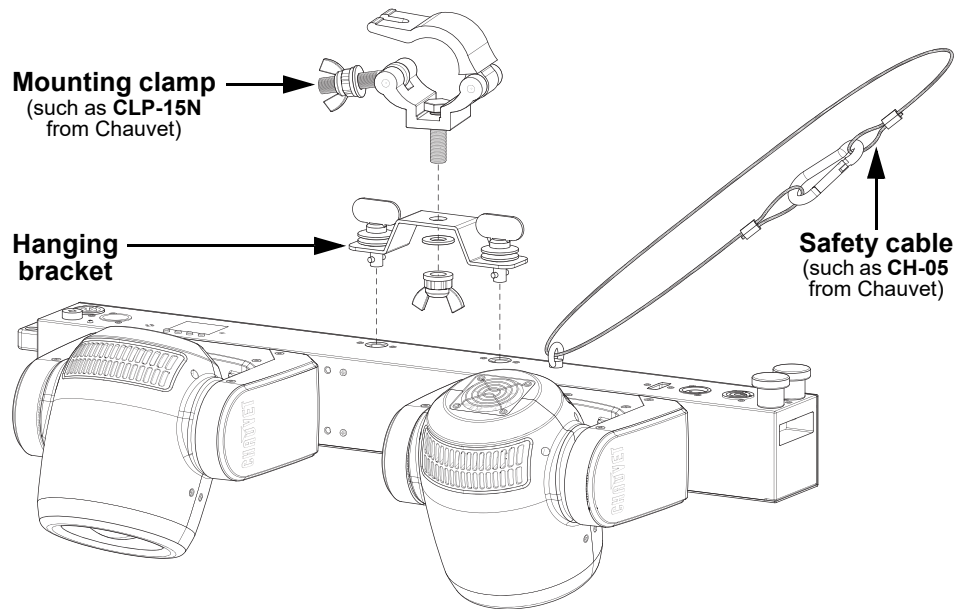

To prevent accidental loosening when using a single mounting clamp, be sure to use a clamp with a captive bolt.

Alignment Tab, Slot, and Pins

To use the alignment tab, slot, and pins to mount products in a straight line:

1. Pull the alignment pins on the first product and hold them in place.

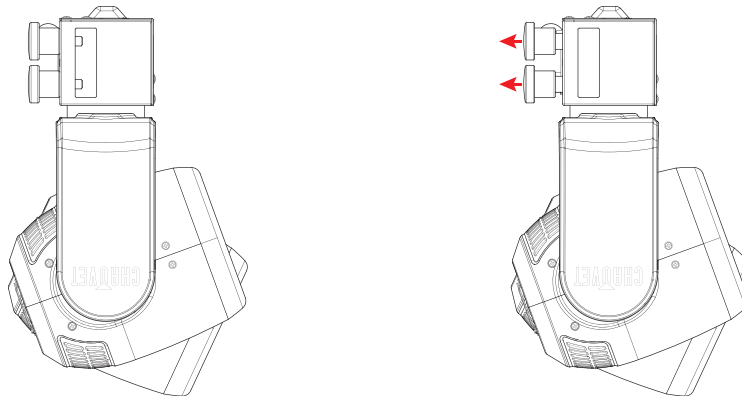

2. Slide the alignment tab of the second product into the alignment slot of the first product.

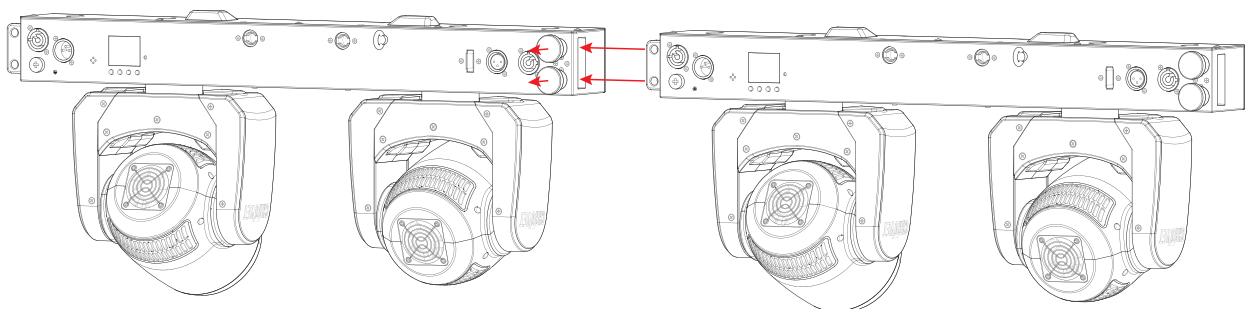

3. Release the alignment pins and adjust until they are secure in the holes of the alignment tab.

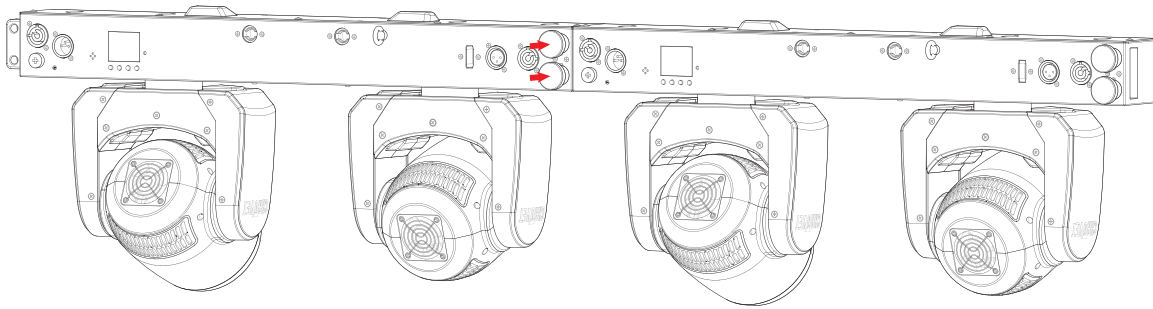

Mounting Diagram with Tripod

The GigBAR Bridge Beam ILS is compatible with tripods which have 1.5 in (37.4 mm) shafts. To mount the product on a tripod:

1. Adjust the tripod to the desired height.
2. Lower the product onto the tripod so the tripod mount holds the shaft of the tripod.
3. Tighten the tripod mount knob.

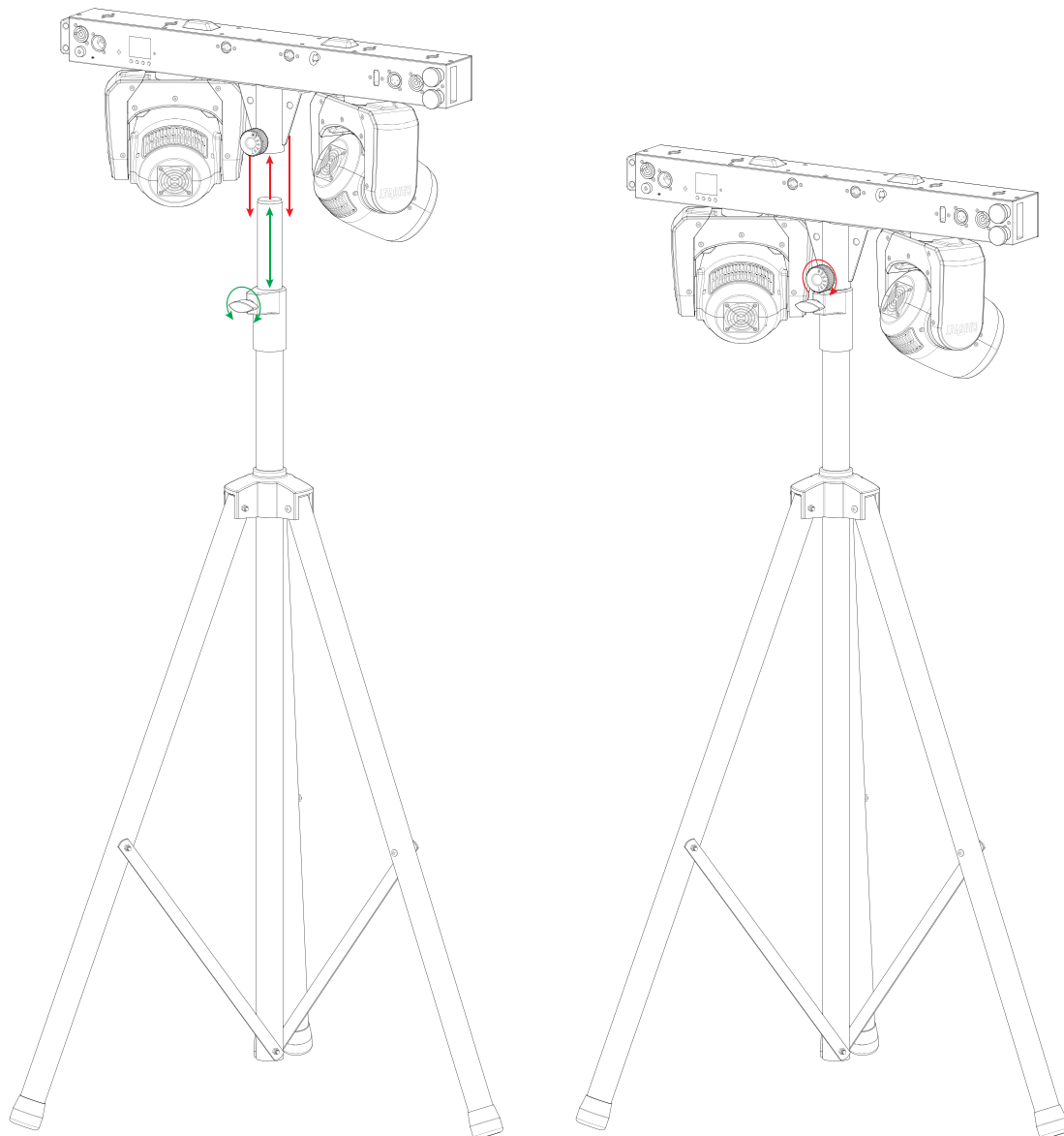

Inverting the Tripod Mount

To invert the tripod mount:

1. Remove the 4 indicated screws from the tripod mount with a hex key.

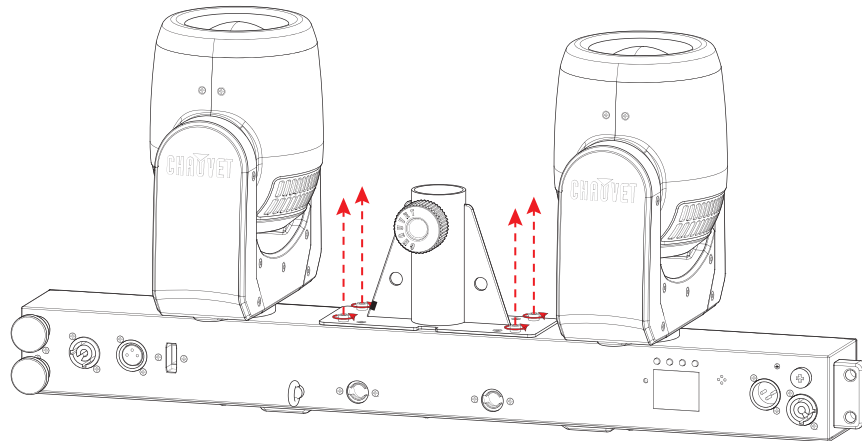



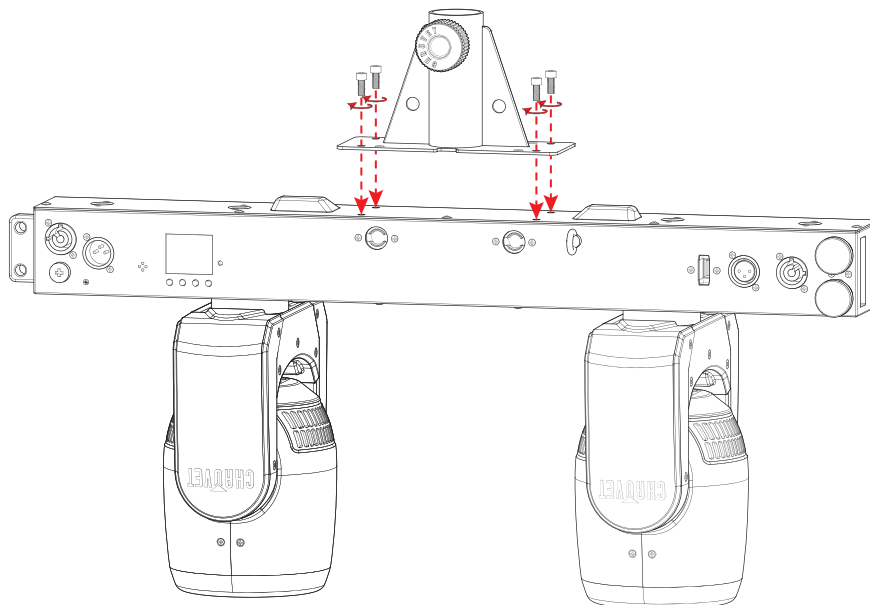

2. Use the 4 screws to install the tripod on the opposite side.



4. Operation

Control Panel Operation

To access the control panel functions, use the four buttons located underneath the display. Please refer to the [Product Overview](#) to see the button locations on the control panel.

Button	Name	Function
	<MENU>	Exits from the current menu or function
	<UP>	Navigates upwards through the menu list and increases the numeric value when in a function
	<DOWN>	Navigates downwards through the menu list and decreases the numeric value when in a function
	<ENTER>	Enables the currently displayed menu or sets the currently selected value into the selected function

Menu Map

Refer to the GigBAR Bridge Beam ILS product page on www.chauvetdj.com for the latest menu map and software.

Main Level	Programming Levels		Description
AUTO	Program	Pro 1–5	Sets auto program show
	Mode	Snap	Selects the transition between auto programs
		Fade	
	Speed	0–99	Sets automatic program speed
	Spot Move	AUTO	Sets the pan and tilt movement of the spots
		M1–M7	
	Spot Speed	0–99	Adjusts the pan and tilt speed of the spots
	Dimmer	0–255	Adjusts the dimmer
Strobe	0–20	Selects the strobe	
Program Time	1–255 (seconds)	Sets the program time	
SOUND	Program	Pro 1–5	Sets auto programs on sound mode
	Sensitivity	0–99	Sets sound sensitivity
	Spot Move	M1–M7	Activates sound-active movements on moving heads
		SOUND	
	Spot Speed	0–99	Adjusts the pan and tilt speed of the spots
	Dimmer	0–255	Adjusts dimmer
	Strobe	0–20	Selects the strobe
	Program Time	1–255 (seconds)	Sets the program time
Sound Lost	Show	The selected program will play automatically	
	Freeze	The entire bar will freeze on the last setting	
	Blackout	The entire bar will blackout	

Main Level	Programming Levels		Description	
MANUAL	Par Red	0–255	Selects the par color	
	Par Green			
	Par Blue			
	Par Amber			
	Par White			
	Par UV		Adjusts the pan angle	
	Pan			
	Tilt			Adjusts the tilt angle
	Red			Sets the beam color
	Green			
	Blue			
	White			
	Dimmer			
	Shutter			Adjusts the strobe rate
	Strip Red			Sets the ring color
Strip Green				
Strip Blue				
Strip White				
DMX	DMX	03CH	Select the DMX channel	
		24CH		
		60CH		
	Address	001–510	Set DMX starting address	
SLAVE			Select for slave mode	
SETUP	RF	COMMON	Enables control of the fixture using any RF remote	
		BIND	Enables control of the GigBAR Bridge Beam ILS using only the RF remote paired to the fixture	
		OFF	Turns infrared off	
	Binding RF		Pairs an RF remote to a specific GigBAR Bridge Beam ILS fixture (Hold and press Blackout button on the RF remote)	
	FOOT	COMMON	Enables control of the fixture using any footswitch	
		BIND	Enables control of the GigBAR Bridge Beam ILS using only the footswitch paired to the fixture	
		OFF	Turns footswitch control off	
	Binding FOOT		Pairs a footswitch to a specific GigBAR Bridge Beam ILS fixture (Hold and press Blackout pedal on the footswitch)	
	DFI	OFF	Disables D-Fi	
		RX	Enables/disables receiving of D-Fi signal	
		TX	Enables/disables transmitting of D-Fi signal	
	DFI Channel	1–16	Selects D-Fi channel	
	Pan1 Reverse	OFF	Enables/disables Moving Head 1 pan reverse. Default set to OFF.	
ON				

Main Level	Programming Levels		Description
SETUP (cont.)	Tilt1 Reverse	OFF	Enables/disables Moving Head 1 tilt reverse. Default set to OFF.
		ON	
	Pan2 Reverse	OFF	Enables/disables Moving Head 2 pan reverse. Default set to OFF.
		ON	
	Tilt2 Reverse	OFF	Enables/disables Moving Head 2 tilt reverse. Default set to OFF.
		ON	
	Pan Ranges	180	180° pan range
		540	540° pan range
		360	360° pan range
	Tilt Ranges	90	90° tilt range
		220	220° tilt range
		180	180° tilt range
	DMX Loss	Hold	Holds the last instruction on signal loss
		Black	Blacks out the product on signal loss
		Auto	Plays auto program on signal loss
		Sound	Plays sound program on signal loss
	Back Light	30S	Sets the back light timer to 30 seconds
		2M	Sets the back light timer to 2 minutes
		AlwaysOn	Sets the back light to stay on
		10S	Sets the back light timer to 10 seconds
Screen Reverse	OFF	Disable reverse display	
	ON	Reverse display	
Totem Mode	DOWN	Restricts the pan and tilt motion for surface/ floor mounting	
	UP	Restricts the pan and tilt motion for overhead mounting	
RESET	NO	Resets to factory defaults	
	YES		
Firmware Update	NO	Follow on-screen instructions to update the firmware	
	YES		
Sys Info	Ver:	V1.01	Displays current firmware version
	Dmx Address:	---	Displays current DMX address
	DFI:	---	Displays D-Fi status

DMX Configuration

The GigBAR Bridge Beam ILS works with a DMX controller. Information about DMX is in the Chauvet DMX Primer, which is available from the Chauvet website chauvetlighting.com/downloads/DMX_Primer_rev05_WO.pdf.

DMX Personalities

The GigBAR Bridge Beam ILS has 3 DMX personalities: **03CH**, **24CH**, and **60CH**.

To select which DMX personality to use, follow the steps below:

1. Press **<MENU>**.
2. Use **<UP>** or **<DOWN>** to select **DMX**.
3. Press **<ENTER>**.
4. Use **<UP>** or **<DOWN>** to select **DMX**.
5. Press **<ENTER>**.
6. Use **<UP>** or **<DOWN>** to select the DMX personality, from **03CH**, **24CH** or **60CH**.
7. Press **<ENTER>**.

Starting Address

The GigBAR Bridge Beam ILS uses up to 60 DMX channels, which defines the highest configurable/recommended address to **453**.

When selecting a starting DMX address, always consider the number of DMX channels the DMX mode uses. If the starting address is set too high, access to some channels could be restricted.

For information about the DMX protocol, download the DMX Primer from www.chauvetdj.com.

To select the starting address, do the following:

1. Press **<MENU>**.
2. Use **<UP>** or **<DOWN>** to select **DMX**.
3. Press **<ENTER>**.
4. Use **<UP>** or **<DOWN>** to select **Address**.
5. Press **<ENTER>**.
6. Use **<UP>** or **<DOWN>** to select the starting address, from **001–510**.
7. Press **<ENTER>**.

D-Fi USB Connectivity

The GigBAR Bridge Beam ILS is able to become a D-Fi wireless receiver/transmitter with the use of the D-Fi USB from Chauvet DJ. Simply set the product's DMX Personality and DMX Address, set the DIP switch D-Fi receiving/transmitting channel, then plug it into the D-Fi USB port.



WARNING! DO NOT plug anything other than a D-Fi USB into the USB type B port. Doing so may cause damage to the product.



Once plugged in, the D-Fi USB will take over the product. Wired DMX and manual display control / menu buttons will be unavailable until the D-Fi USB is unplugged. The priority levels are:

1. D-Fi USB
2. Wired DMX
3. Manual Digital Display/Menu Buttons

D-Fi USB Compatibility

The D-Fi USB can receive a DMX signal from the D-Fi Hub and the FlareCON Air 2 as well as other D-Fi USB products.

D-Fi USB Configuration

1. Set the DMX Personality and DMX address on the GigBAR Bridge Beam ILS.
2. Use the Chart provided to set **BOTH**:
 - the Channel, and then
 - The Receiving or Transmitting option

NOTE: DIP Switch 5 is for Transmitting OR Receiving, please choose carefully.

D-Fi USB DIP Switch Channels

Receiving					Receiving					Transmitting					Transmitting								
Ch.	1	2	3	4	T/R	Ch.	1	2	3	4	T/R	Ch.	1	2	3	4	T/R	Ch.	1	2	3	4	T/R
1	<input type="checkbox"/>	<input type="checkbox"/>	<input type="checkbox"/>	<input type="checkbox"/>	<input type="checkbox"/>	9	<input type="checkbox"/>	<input type="checkbox"/>	<input type="checkbox"/>	<input type="checkbox"/>	<input type="checkbox"/>	1	<input type="checkbox"/>	<input type="checkbox"/>	<input type="checkbox"/>	<input type="checkbox"/>	<input type="checkbox"/>	9	<input type="checkbox"/>	<input type="checkbox"/>	<input type="checkbox"/>	<input type="checkbox"/>	<input type="checkbox"/>
2	<input type="checkbox"/>	<input type="checkbox"/>	<input type="checkbox"/>	<input type="checkbox"/>	<input type="checkbox"/>	10	<input type="checkbox"/>	<input type="checkbox"/>	<input type="checkbox"/>	<input type="checkbox"/>	<input type="checkbox"/>	2	<input type="checkbox"/>	<input type="checkbox"/>	<input type="checkbox"/>	<input type="checkbox"/>	<input type="checkbox"/>	10	<input type="checkbox"/>	<input type="checkbox"/>	<input type="checkbox"/>	<input type="checkbox"/>	<input type="checkbox"/>
3	<input type="checkbox"/>	<input type="checkbox"/>	<input type="checkbox"/>	<input type="checkbox"/>	<input type="checkbox"/>	11	<input type="checkbox"/>	<input type="checkbox"/>	<input type="checkbox"/>	<input type="checkbox"/>	<input type="checkbox"/>	3	<input type="checkbox"/>	<input type="checkbox"/>	<input type="checkbox"/>	<input type="checkbox"/>	<input type="checkbox"/>	11	<input type="checkbox"/>	<input type="checkbox"/>	<input type="checkbox"/>	<input type="checkbox"/>	<input type="checkbox"/>
4	<input type="checkbox"/>	<input type="checkbox"/>	<input type="checkbox"/>	<input type="checkbox"/>	<input type="checkbox"/>	12	<input type="checkbox"/>	<input type="checkbox"/>	<input type="checkbox"/>	<input type="checkbox"/>	<input type="checkbox"/>	4	<input type="checkbox"/>	<input type="checkbox"/>	<input type="checkbox"/>	<input type="checkbox"/>	<input type="checkbox"/>	12	<input type="checkbox"/>	<input type="checkbox"/>	<input type="checkbox"/>	<input type="checkbox"/>	<input type="checkbox"/>
5	<input type="checkbox"/>	<input type="checkbox"/>	<input type="checkbox"/>	<input type="checkbox"/>	<input type="checkbox"/>	13	<input type="checkbox"/>	<input type="checkbox"/>	<input type="checkbox"/>	<input type="checkbox"/>	<input type="checkbox"/>	5	<input type="checkbox"/>	<input type="checkbox"/>	<input type="checkbox"/>	<input type="checkbox"/>	<input type="checkbox"/>	13	<input type="checkbox"/>	<input type="checkbox"/>	<input type="checkbox"/>	<input type="checkbox"/>	<input type="checkbox"/>
6	<input type="checkbox"/>	<input type="checkbox"/>	<input type="checkbox"/>	<input type="checkbox"/>	<input type="checkbox"/>	14	<input type="checkbox"/>	<input type="checkbox"/>	<input type="checkbox"/>	<input type="checkbox"/>	<input type="checkbox"/>	6	<input type="checkbox"/>	<input type="checkbox"/>	<input type="checkbox"/>	<input type="checkbox"/>	<input type="checkbox"/>	14	<input type="checkbox"/>	<input type="checkbox"/>	<input type="checkbox"/>	<input type="checkbox"/>	<input type="checkbox"/>
7	<input type="checkbox"/>	<input type="checkbox"/>	<input type="checkbox"/>	<input type="checkbox"/>	<input type="checkbox"/>	15	<input type="checkbox"/>	<input type="checkbox"/>	<input type="checkbox"/>	<input type="checkbox"/>	<input type="checkbox"/>	7	<input type="checkbox"/>	<input type="checkbox"/>	<input type="checkbox"/>	<input type="checkbox"/>	<input type="checkbox"/>	15	<input type="checkbox"/>	<input type="checkbox"/>	<input type="checkbox"/>	<input type="checkbox"/>	<input type="checkbox"/>
8	<input type="checkbox"/>	<input type="checkbox"/>	<input type="checkbox"/>	<input type="checkbox"/>	<input type="checkbox"/>	16	<input type="checkbox"/>	<input type="checkbox"/>	<input type="checkbox"/>	<input type="checkbox"/>	<input type="checkbox"/>	8	<input type="checkbox"/>	<input type="checkbox"/>	<input type="checkbox"/>	<input type="checkbox"/>	<input type="checkbox"/>	16	<input type="checkbox"/>	<input type="checkbox"/>	<input type="checkbox"/>	<input type="checkbox"/>	<input type="checkbox"/>

DMX Channel Assignments and Values

Zones for DMX Control

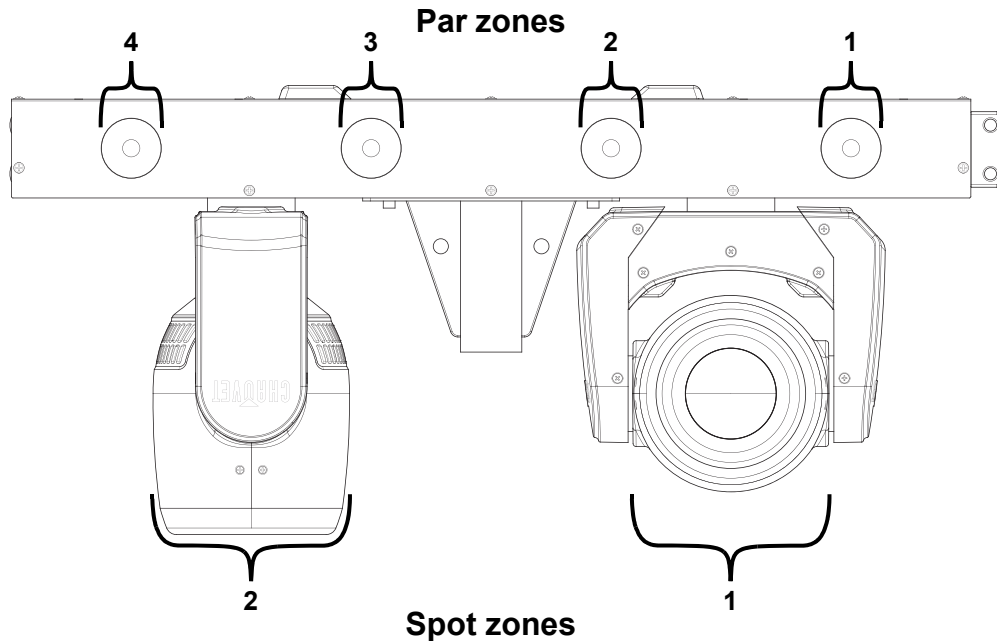

DMX Charts

03CH

Channel	Function	Value	Percent/Setting
1	Auto program (Sound-active program when Ch2 is 128 ⇔ 255)	000 ⇔ 005	Blackout
		006 ⇔ 055	Auto program 1
		056 ⇔ 105	Auto program 2
		106 ⇔ 155	Auto program 3
		156 ⇔ 205	Auto program 4
		206 ⇔ 255	Auto program 5
2	Speed/sound sensitivity	000 ⇔ 127	Auto program speed, slow to fast
		128 ⇔ 255	Sound sensitivity, low to high
3	Pan/Tilt speed	000 ⇔ 255	Pan/tilt speed, slow to fast

24CH

Channel	Function	Value	Percent/Setting
1	Par red	000 ⇔ 255	0–100%
2	Par green	000 ⇔ 255	0–100%
3	Par blue	000 ⇔ 255	0–100%
4	Par amber	000 ⇔ 255	0–100%
5	Par white	000 ⇔ 255	0–100%
6	Par UV	000 ⇔ 255	0–100%
7	Par strobe	000 ⇔ 011	No function
		012 ⇔ 250	Strobe speed, slow to fast
		251 ⇔ 255	Strobe to sound
8	Beam pan	000 ⇔ 255	0–100%
9	Beam fine pan	000 ⇔ 255	0–100% (16-bit)

Channel	Function	Value	Percent/Setting
10	Beam tilt	000 ⇔ 255	0–100%
11	Beam fine tilt	000 ⇔ 255	0–100% (16-bit)
12	Beam pan/tilt speed	000 ⇔ 255	Pan/tilt speed, fast to slow
13	Beam red	000 ⇔ 255	0–100%
14	Beam green	000 ⇔ 255	0–100%
15	Beam blue	000 ⇔ 255	0–100%
16	Beam white	000 ⇔ 255	0–100%
17	Beam dimmer	000 ⇔ 255	0–100%
18	Beam strobe	000 ⇔ 005	No function
		006 ⇔ 255	Strobe speed, slow to fast
19	Ring red	000 ⇔ 255	0–100%
20	Ring green	000 ⇔ 255	0–100%
21	Ring blue	000 ⇔ 255	0–100%
22	Ring white	000 ⇔ 255	0–100%
23	Ring auto programs	000 ⇔ 031	No function
		032 ⇔ 063	Automatic program 1
		064 ⇔ 095	Automatic program 2
		096 ⇔ 127	Automatic program 3
		128 ⇔ 159	Automatic program 4
		160 ⇔ 191	Automatic program 5
		192 ⇔ 223	Automatic program 6
	224 ⇔ 255	Automatic program 7	
24	Ring auto speed	000 ⇔ 255	Auto speed, slow to fast

60Ch

Channel	Function	Value	Percent/Setting
1	Par 1 red	000 ⇔ 255	0–100%
2	Par 1 green	000 ⇔ 255	0–100%
3	Par 1 blue	000 ⇔ 255	0–100%
4	Par 1 amber	000 ⇔ 255	0–100%
5	Par 1 white	000 ⇔ 255	0–100%
6	Par 1 UV	000 ⇔ 255	0–100%
7	Par 1 strobe	000 ⇔ 011	No function
		012 ⇔ 250	Strobe speed, slow to fast
		251 ⇔ 255	Strobe to sound
8	Par 2 red	000 ⇔ 255	0–100%
9	Par 2 green	000 ⇔ 255	0–100%
10	Par 2 blue	000 ⇔ 255	0–100%
11	Par 2 amber	000 ⇔ 255	0–100%
12	Par 2 white	000 ⇔ 255	0–100%
13	Par 2 UV	000 ⇔ 255	0–100%
14	Par 2 strobe	000 ⇔ 011	No function
		012 ⇔ 250	Strobe speed, slow to fast
		251 ⇔ 255	Strobe to sound
15	Par 3 red	000 ⇔ 255	0–100%
16	Par 3 green	000 ⇔ 255	0–100%

Channel	Function	Value	Percent/Setting
17	Par 3 blue	000 ⇔ 255	0–100%
18	Par 3 amber	000 ⇔ 255	0–100%
19	Par 3 white	000 ⇔ 255	0–100%
20	Par 3 UV	000 ⇔ 255	0–100%
21	Par 3 strobe	000 ⇔ 011	No function
		012 ⇔ 250	Strobe speed, slow to fast
		251 ⇔ 255	Strobe to sound
22	Par 4 red	000 ⇔ 255	0–100%
23	Par 4 green	000 ⇔ 255	0–100%
24	Par 4 blue	000 ⇔ 255	0–100%
25	Par 4 amber	000 ⇔ 255	0–100%
26	Par 4 white	000 ⇔ 255	0–100%
27	Par 4 UV	000 ⇔ 255	0–100%
28	Par 4 strobe	000 ⇔ 011	No function
		012 ⇔ 250	Strobe speed, slow to fast
		251 ⇔ 255	Strobe to sound
29	Beam 1 pan	000 ⇔ 255	0–100%
30	Beam 1 fine pan	000 ⇔ 255	0–100% (16-bit)
31	Beam 1 tilt	000 ⇔ 255	0–100%
32	Beam 1 fine tilt	000 ⇔ 255	0–100% (16-bit)
33	Beam 1 pan/tilt speed	000 ⇔ 255	Pan/tilt speed, fast to slow
34	Beam 1 red	000 ⇔ 255	0–100%
35	Beam 1 green	000 ⇔ 255	0–100%
36	Beam 1 blue	000 ⇔ 255	0–100%
37	Beam 1 white	000 ⇔ 255	0–100%
38	Beam 1 dimmer	000 ⇔ 255	0–100%
39	Beam 1 strobe	000 ⇔ 005	No function
		006 ⇔ 255	Strobe speed, slow to fast
40	Beam 2 pan	000 ⇔ 255	0–100%
41	Beam 2 fine pan	000 ⇔ 255	0–100% (16-bit)
42	Beam 2 tilt	000 ⇔ 255	0–100%
43	Beam 2 fine tilt	000 ⇔ 255	0–100% (16-bit)
44	Beam 2 pan/tilt speed	000 ⇔ 255	Pan/tilt speed, fast to slow
45	Beam 2 red	000 ⇔ 255	0–100%
46	Beam 2 green	000 ⇔ 255	0–100%
47	Beam 2 blue	000 ⇔ 255	0–100%
48	Beam 2 white	000 ⇔ 255	0–100%
49	Beam 2 dimmer	000 ⇔ 255	0–100%
50	Beam 2 strobe	000 ⇔ 005	No function
		006 ⇔ 255	Strobe speed, slow to fast
51	Ring 1 red	000 ⇔ 255	0–100%
52	Ring 1 green	000 ⇔ 255	0–100%
53	Ring 1 blue	000 ⇔ 255	0–100%
54	Ring 1 white	000 ⇔ 255	0–100%
55	Ring 2 red	000 ⇔ 255	0–100%
56	Ring 2 green	000 ⇔ 255	0–100%
57	Ring 2 blue	000 ⇔ 255	0–100%

Channel	Function	Value	Percent/Setting
58	Ring 2 white	000 ⇔ 255	0–100%
59	Ring auto programs	000 ⇔ 031	No function
		032 ⇔ 063	Automatic program 1
		064 ⇔ 095	Automatic program 2
		096 ⇔ 127	Automatic program 3
		128 ⇔ 159	Automatic program 4
		160 ⇔ 191	Automatic program 5
		192 ⇔ 223	Automatic program 6
		224 ⇔ 255	Automatic program 7
60	Ring auto speed	000 ⇔ 255	Auto speed, slow to fast

Standalone Configuration

Set the product in one of the standalone modes to operate without a DMX controller.



Never connect a product that is operating in any standalone mode to a DMX string connected to a DMX controller. Products in standalone mode may transmit DMX signals that could interfere with the DMX signals from the controller.

Mixed Effect Modes

The GigBAR Bridge Beam ILS has mixed effect programs which can run in automatic or sound-active mode.

Automatic Mixed Effect

To run a mixed effect program in automatic mode:

1. Use **<UP>** or **<DOWN>** to select **AUTO**.
2. Press **<ENTER>** to activate **AUTO** mode.
3. Press **<ENTER>** again to access the **AUTO** menu.

Sound-Active Mixed Effect

To run a mixed effect program in sound-active mode:

1. Use **<UP>** or **<DOWN>** to select **SOUND**.
2. Press **<ENTER>** to activate **SOUND** mode.
3. Press **<ENTER>** again to access the **SOUND** menu.

Program Selection

To select a mixed-effect program:

1. Access the **AUTO** menu or the **SOUND** menu.
2. Use **<UP>** or **<DOWN>** to select **Program**.
3. Press **<ENTER>**.
4. Use **<UP>** or **<DOWN>** to select from **Pro 1–5**.
5. Press **<ENTER>**.

Program Mode

To select between Snap and Fade mode for an automatic program:

1. Access the **AUTO** menu.
2. Use **<UP>** or **<DOWN>** to select **Mode**.
3. Press **<ENTER>**.
4. Use **<UP>** or **<DOWN>** to select between **Snap** (snap transition between programs) and **Fade** (fading transition between programs).
5. Press **<ENTER>**.

Program Speed

To adjust the speed of an automatic program:

1. Access the **AUTO** menu.
2. Use **<UP>** or **<DOWN>** to select **Speed**.
3. Press **<ENTER>**.
4. Use **<UP>** or **<DOWN>** to select to adjust the program speed from **0–99**.
5. Press **<ENTER>**.

Sound Sensitivity

To adjust the sound sensitivity of a sound-active program:

1. Access the **SOUND** menu.
2. Use **<UP>** or **<DOWN>** to select **Sensitivity**.
3. Press **<ENTER>**.
4. Use **<UP>** or **<DOWN>** to increase or decrease the sensitivity from **0–99**.
5. Press **<ENTER>**.



The product will only respond to low frequencies of music (bass and drums).

Program Beam Movement

To select the movement macro for a mixed effect program:

1. Access the **AUTO** menu or the **SOUND** menu.
2. Use <UP> or <DOWN> to select **Spot Move**.
3. Press <ENTER>.
4. Use <UP> or <DOWN> to select from **AUTO** or **M1–7**.
5. Press <ENTER>.

Program Beam Speed

To set the speed of the beam movement for a mixed effect program:

1. Access the **AUTO** menu or the **SOUND** menu.
2. Use <UP> or <DOWN> to select **Spot Speed**.
3. Press <ENTER>.
4. Use <UP> or <DOWN> to increase or decrease the speed from **0–99**.
5. Press <ENTER>.

Dimmer

To adjust the intensity of a mixed effect program:

1. Access the **AUTO** menu or the **SOUND** menu.
2. Use <UP> or <DOWN> to select **Dimmer**.
3. Press <ENTER>.
4. Use <UP> or <DOWN> to increase or decrease the intensity from **0–255**.
5. Press <ENTER>.

Strobe

To set the strobe rate of a mixed effect program:

1. Access the **AUTO** menu or the **SOUND** menu.
2. Use <UP> or <DOWN> to select **Strobe**.
3. Press <ENTER>.
4. Use <UP> or <DOWN> to set the strobe from **0–20**.
5. Press <ENTER>.

Program Time

To set the time of a mixed effect program:

1. Access the **AUTO** menu or the **SOUND** menu.
2. Use <UP> or <DOWN> to select **Program Time**.
3. Press <ENTER>.
4. Use <UP> or <DOWN> to set the timer from **1–255** (seconds).
5. Press <ENTER>.

Sound Lost

To set the product's behavior when a sound-active program detects no sound:

1. Access the **SOUND** menu.
2. Use <UP> or <DOWN> to select **Sound Lost**.
3. Press <ENTER>.
4. Use <UP> or <DOWN> to choose from **Show** (the mixed effect program will switch to automatic mode), **Freeze** (the output will freeze on the last setting), or **Blackout** (the product will black out).
5. Press <ENTER>.

Manual Mode

To manually set the GigBAR Bridge Beam ILS to a static output:

1. Use <UP> or <DOWN> to select **MANUAL**.
2. Press <ENTER> to activate **MANUAL** mode.
3. Press <ENTER> again to access the **MANUAL** menu.
4. Use <UP> or <DOWN> to select a setting, from **Par Red, Par Green, Par Blue, Par Amber, Par White, Par UV, Pan, Tilt, Red, Green, Blue, White, Dimmer, Shutter, Strip Red, Strip Green, Strip Blue, or Strip White**. ("Strip" here refers to the LED rings on the moving heads.)
5. Press <ENTER>.
6. Use <UP> or <DOWN> to increase or decrease the selected value from **0–255**.
7. Press <ENTER>.

Settings Configuration

To access the **SETUP** menu:

1. Use **<UP>** or **<DOWN>** to select **SETUP**.
2. Press **<ENTER>** to temporarily activate **SETUP** mode.
3. Press **<ENTER>** again to access the **SETUP** menu.



The product will revert to the previous mode after 30 seconds of inactivity.

D-Fi Settings

D-Fi Mode

To select the D-Fi mode:

1. Access the **SETUP** menu.
2. Use **<UP>** or **<DOWN>** to select **DFI**.
3. Press **<ENTER>**.
4. Use **<UP>** or **<DOWN>** to select the mode, from **OFF** (disables D-Fi), **RX** (receiver mode), or **TX** (transmitter mode).
5. Press **<ENTER>**.



Caution: D-Fi 2.4 GHz operation can be interrupted or inhibited by obstructions between the transmitter and receiver such as structures or people. For best results, keep the line of sight clear.



The maximum unobstructed distance between a D-Fi 2.4 GHz transmitter and receiver is 600 ft (183 m).

D-Fi Channel

To select the channel for D-Fi reception or transmission:

1. Access the **SETUP** menu.
2. Use **<UP>** or **<DOWN>** to select **DFI Channel**.
3. Press **<ENTER>**.
4. Use **<UP>** or **<DOWN>** to increase or decrease the channel from **1–16**.
5. Press **<ENTER>**.

Pan Reverse

To set the orientation of the pan on the GigBAR Bridge Beam ILS:

1. Access the **SETUP** menu.
2. Use **<UP>** or **<DOWN>** to select **Pan1 Reverse** (for Beam 1) or **Pan2 Reverse** (for Beam 2).
3. Press **<ENTER>**.
4. Use **<UP>** or **<DOWN>** to select **OFF** (normal pan motion) or **ON** (reversed pan motion).
5. Press **<ENTER>**.

Tilt Reverse

To manually set the orientation of the tilt on the GigBAR Bridge Beam ILS:

1. Access the **SETUP** menu.
2. Use **<UP>** or **<DOWN>** to select **Tilt1 Reverse** (for Beam 1) or **Tilt2 Reverse** (for Beam 2).
3. Press **<ENTER>**.
4. Use **<UP>** or **<DOWN>** to select **OFF** (normal tilt motion) or **ON** (reversed tilt motion).
5. Press **<ENTER>**.

Pan Range

To set the maximum angle of the pan on the GigBAR Bridge Beam ILS:

1. Access the **SETUP** menu.
2. Use **<UP>** or **<DOWN>** to select **Pan Ranges**.
3. Press **<ENTER>**.
4. Use **<UP>** or **<DOWN>** to set the pan angle from **180** (180°), **540** (540°), or **360** (360°).
5. Press **<ENTER>**.

Tilt Range

To set the maximum angle of the tilt on the GigBAR Bridge Beam ILS:

1. Access the **SETUP** menu.
2. Use **<UP>** or **<DOWN>** to select **Tilt Ranges**.
3. Press **<ENTER>**.
4. Use **<UP>** or **<DOWN>** to set the tilt angle from **90** (90°), **220** (270°), or **180** (180°).
5. Press **<ENTER>**.

DMX Loss

To set the product's behavior when a DMX signal is lost:

1. Access the **SETUP** menu.
2. Use **<UP>** or **<DOWN>** to select **DMX Loss**.
3. Press **<ENTER>**.
4. Use **<UP>** or **<DOWN>** to select from **Hold** (freeze on last instruction), **Black** (black out the product), **Auto** (play an auto program), or **Sound** (play a sound-active program).
5. Press **<ENTER>**.

Back Light Timer

To set how long the display will stay on during a period of inactivity:

1. Access the **SETUP** menu.
2. Use **<UP>** or **<DOWN>** to select **Back Light**.
3. Press **<ENTER>**.
4. Use **<UP>** or **<DOWN>** to select from **30S** (30 seconds), **2M** (2 minutes), **Always On** (indefinitely), or **10S** (10 seconds).
5. Press **<ENTER>**.

Screen Reverse

To reverse the display screen or disable a reversed display screen:

1. Access the **SETUP** menu.
2. Use **<UP>** or **<DOWN>** to select **Screen Reverse**.
3. Press **<ENTER>**.
4. Use **<UP>** or **<DOWN>** to select from **OFF** (disable screen reverse), or **ON** (enables screen reverse).
5. Press **<ENTER>**.

Totem Mode

To restrict pan and tilt motion for overhead or surface mounting, follow the instructions below:

1. Access the **SETUP** menu.
2. Use **<UP>** or **<DOWN>** to select **Totem Mode**.
3. Press **<ENTER>**.
4. Use **<UP>** or **<DOWN>** to select from **UP** (for overhead mounting), or **DOWN** (for surface/floor mounting).
5. Press **<ENTER>**.

Factory Reset

To reset specific functions or the entire product, do the following:

1. Access the **SETUP** menu.
2. Use **<UP>** or **<DOWN>** to select **RESET**.
3. Press **<ENTER>**.
4. Use **<UP>** or **<DOWN>** to select **YES** (to reset the product configuration) or **NO** (to cancel).
5. Press **<ENTER>**.

Firmware Update

To update the firmware of the GigBAR Bridge Beam ILS:

1. Access the **SETUP** menu.
2. Use **<UP>** or **<DOWN>** to select **Firmware Update**.
3. Press **<ENTER>**.
4. Use **<UP>** or **<DOWN>** to select **YES** (perform a firmware update) or **NO** (to cancel).
5. Press **<ENTER>**.
6. If **YES**, follow the instructions on the display to perform the firmware update.

Operation

System Information

To view the system information (the current firmware version, DMX address, and D-Fi mode):

1. Use **<UP>** or **<DOWN>** to select **Sys Info**.
2. Press **<ENTER>**.

Wireless Footswitch Configuration

Footswitch Overview

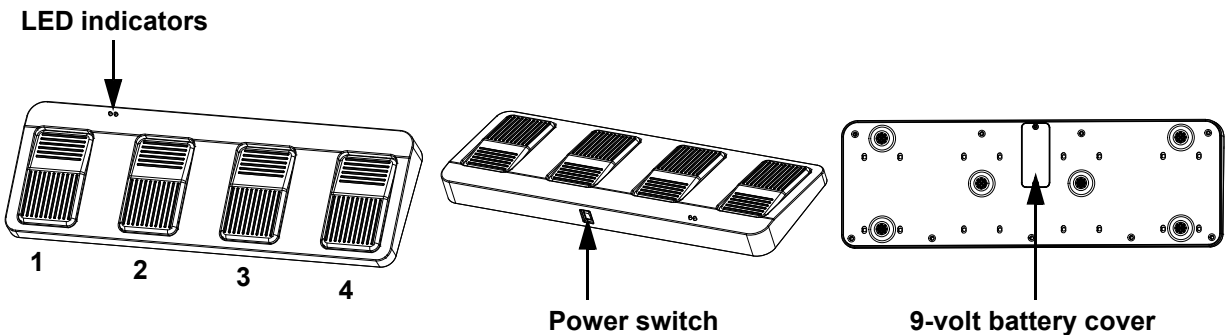

Footswitch Operation

The included wireless footswitch provides quick access to preset colors, color-change programs, and sound-activation through the GigBAR Bridge Beam ILS microphone.

To use the footswitch:

1. Access the **SETUP** menu.
2. Use **<UP>** or **<DOWN>** to select **FOOT**.
3. Press **<ENTER>**.
4. Use **<UP>** or **<DOWN>** to select **COMMON** (to use with any footswitch) or **BIND** (to pair a footswitch to a specific GigBAR Bridge Beam ILS fixture) or **OFF** (to disable operation).
5. Press **<ENTER>**.
6. Use the chart below to activate the desired function.

Pedal	Action	Function
1 (Auto programs)	Tap pedal to activate, then tap to navigate to desired function	Auto programs
2 (Sound mode)	Press and hold	Sound-active programs
3 (Static colors)	Tap	Cycles colors in Auto/ Sound mode (Pars ONLY)
4 (Blackout)	Tap	Blackout



- The GigBAR Bridge Beam ILS footswitch will work properly in any mode, with a maximum unobstructed distance of 100 ft (30.5 m).
- The settings will be saved if there is no operation after 2 seconds.
- The Footswitch will not work in Master/ Slave mode

Footswitch Binding

The GigBAR Bridge Beam ILS can be paired with a wireless footswitch (sold separately). To pair the GigBAR Bridge Beam ILS with a wireless footswitch:

1. Connect the GigBAR Bridge Beam ILS to power. Turn the wireless footswitch on.
2. On the GigBAR Bridge Beam ILS, access the **SETUP** menu.
3. Use **<UP>** or **<DOWN>** to select **Binding FOOT**.
4. Press **<ENTER>**.
5. Press and hold the **Blackout** pedal on the footswitch.

Footswitch Battery

The wireless footswitch uses a 9-volt battery located under the battery cover on the bottom of the product, which can be replaced when necessary.

Battery Replacement

To replace the battery in the wireless footswitch:

1. Turn the power switch to the Off position.
2. Remove the battery cover by removing 2 screws with a Phillips-head screwdriver.
3. Remove the old battery from the housing and unplug it from the leads.
4. Replace with a new 9-volt battery, ensuring that the positive (+) and negative (-) leads correspond to the correct electrodes on the battery.
5. Place the battery into the housing and cover with the battery cover.
6. Secure the battery cover with the 2 Phillips-head screws.



Do NOT over-tighten the screws!

RFC Remote Control

It is possible to operate the GigBAR Bridge Beam ILS with the GigBAR RF Remote (sold separately).

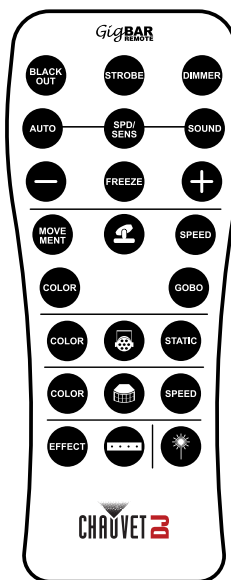

For more information about using an RFC or RFC-XL remote, download the User Manuals from www.chauvetdj.com

RFC Control Mode

The RFC-XL can control multiple products at once, whether in defined groups or in public mode. To set the GigBAR Bridge Beam ILS to public RF control, bound control, or to disable RF control:

1. Access the **SETUP** menu.
2. Use **<UP>** or **<DOWN>** to select **RF**.
3. Press **<ENTER>**.
4. Use **<UP>** or **<DOWN>** to select **COMMON** (to use with any GigBAR RF Remote) or **BIND** (to pair an RF remote to a specific GigBAR Bridge Beam ILS) or **OFF** (to disable RF operation).
5. Press **<ENTER>**.

RFC Remote Binding

To bind the GigBAR Bridge Beam ILS in **BIND** mode to a GigBAR RF Remote:

1. Access the **SETUP** menu.
2. Use **<UP>** or **<DOWN>** to select **Binding RF**.
3. Press **<ENTER>**.
4. Press and hold **<BLACK OUT>** on the RF remote until it blinks to link the fixture to that RF remote.

RFC Remote Control Operation

To operate the product with the GigBAR RF remote, set the product to [AUTO](#), [SOUND](#), or [MANUAL](#) mode, then press any button on the remote.

Black Out

To black out the product with the RF remote, Press **<BLACK OUT>**.

This will turn off all lights until the button is pressed again.

NOTE: The RF remote will not respond to any inputs when Black Out is activated. If the product does not respond when a button is pressed, try pressing **<BLACK OUT>**. Black Out may be active.

Strobe

To activate strobe in manual mode using the RF remote:

1. Press **<STROBE>** on the RF remote.
2. Press **<+>** or **<->** to adjust the strobe.

Dimmer

To adjust the dimmer using the RF remote:

1. Press **<DIMMER>** on the RF remote.
2. Press **<+>** or **<->** to adjust the brightness.

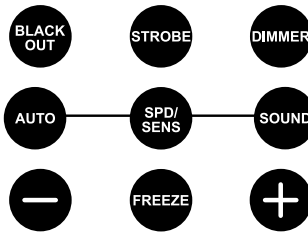

Automatic Mode

Automatic mode will enable the user to run the automatic programs on the product.

To turn on Automatic mode with the RF remote:

1. Press **<AUTO>** on the RF remote.
2. Press **<+>** or **<->** to choose between the different auto programs.

Speed

To adjust the auto program/spot speed with the RF remote:

1. Press **<SPD>** on the RF remote.
2. Press **<+>** or **<->** to increase or decrease the program speed.

Sound-Active Mode

To turn on Sound-Active mode with the RF remote:

1. Press and hold **<SOUND>** on the RF remote.
2. Press **<+>** or **<->** to select a sound-active program.

To adjust the sound sensitivity:

1. Press **<SENS>** on the RF remote.
2. Press **<+>** or **<->** to increase or decrease the sensitivity.

Freeze

To pause an auto program using the RF remote, press **<FREEZE>**.

Beams Program

To select a program for the Beams using an RF remote:

1. Press the **Moving Head icon button** on the RF remote.
2. Press **<MOVE MENT>** on the RF remote.
3. Press **<+>** or **<->** to change the movement program.

Beams XY Speed

To adjust the pan/tilt speed of the Beams using an RF remote:

1. Press the **Moving Head icon button** on the RF remote.
2. Press **<SPEED>** on the RF remote.
3. Press **<+>** or **<->** to increase or decrease the pan/tilt speed.

Beams Color

To select a color for the Beams using an RF remote:

1. Press the **Moving Head icon button** on the RF remote.
2. Press **<COLOR>** on the RF remote.
3. Press **<+>** or **<->** to scroll through the color wheel.

Par Program

To select a program for the Pars using an RF remote:

1. Press the **Par icon button** on the RF remote.
2. Press **<COLOR>** on the RF remote.
3. Press **<+>** or **<->** to scroll through the color programs.

Par Color

To select a static color for the Pars using an RF remote:

1. Press the **Par icon button** on the RF remote.
2. Press **<STATIC>** on the RF remote.
3. Press **<+>** or **<->** to scroll through the static colors.

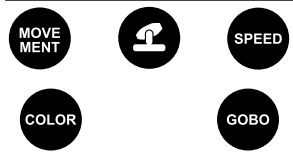

- The individual fixture icon buttons can also be used to turn on and off the selected functions.
- Any setting on the RF remote will be saved until the system is rebooted. The system will revert to Auto Mode after reboot.

Wired Master/Slave Mode

The Master/Slave mode allows a single GigBAR Bridge Beam ILS product (the “master”) to control the actions of one or more GigBAR Bridge Beam ILS products (the “slaves”) without the need of a DMX controller. The master product will be set to operate in either standalone mode or with the GigBAR RF remote, while the slave products will be set to operate in slave mode. Once set and connected, the slave products will operate in unison with the master product.

Configure the products as indicated below.

Slave products:

1. Use **<UP>** or **<DOWN>** to select **SLAVE**.
2. Press **<ENTER>**.
3. Connect the DMX input of the first slave product to the DMX output of the master product.
4. Connect the DMX input of the subsequent slave products to the DMX output of the previous slave product.
5. Finish setting and connecting all the slave products.

Master product:

1. Set the master product to operate in standalone mode or with the GigBAR RF remote.
2. Make the master product the first product in the DMX daisy chain.



- **Configure all the slave products before connecting the master to the daisy chain.**
- **Never connect a DMX controller to a DMX string configured for Master/Slave operation because the controller may interfere with the signals from the master.**
- **Do not connect more than 31 slaves to the master.**

D-Fi Master/Slave Mode

The D-Fi settings allow a single GigBAR Bridge Beam ILS product (the “master”) to control the actions of one or more GigBAR Bridge Beam ILS products (the “slaves”) without the need of a DMX controller or DMX cables. The master (transmitter) product will be set to operate in standalone mode, while the slave (receiver) products will be set to operate in either standalone mode or with the GigBAR RF remote. Once set and connected, the slave products will operate in unison with the master product.

Configure the products as indicated below.

Slave products:

1. Set the [D-Fi Mode](#) to **RX**.
2. Set the [D-Fi Channel](#).
3. Press **<MENU>** repeatedly to return to the main level of the menu.
4. Use **<UP>** or **<DOWN>** to select **SLAVE**.
5. Press **<ENTER>**.
6. Finish setting and connecting all the slave products.

Master product:

1. Set the [D-Fi Mode](#) to **TX**.
2. Set the [D-Fi Channel](#) to the same channel as the slave products.
3. Set the master product to operate in standalone mode or with the GigBAR RF remote.



- **All products must be set to the same DMX personality, DMX address, and D-Fi channel.**
- **Configure all the slave products before configuring the master to transmit.**
- **Never connect a DMX controller to a D-Fi channel configured for Master/Slave operation because the controller may interfere with the signals from the master.**

5. Maintenance

Product Maintenance

Dust build-up reduces light output performance and can cause overheating. This can lead to reduction of the light source's life and/or mechanical wear. To maintain optimum performance and minimize wear, clean all lighting products at least twice a month. However, be aware that usage and environmental conditions could be contributing factors to increase the cleaning frequency.

To clean the product, follow the instructions below:

1. Unplug the product from power.
2. Wait until the product is at room temperature.
3. Use a vacuum (or dry compressed air) and a soft brush to remove dust collected on the external surface/vents.
4. Clean all transparent surfaces with a mild soap solution, ammonia-free glass cleaner, or isopropyl alcohol.
5. Apply the solution directly to a soft, lint free cotton cloth or a lens cleaning tissue.
6. Softly drag any dirt or grime to the outside of the transparent surface.
7. Gently polish the transparent surfaces until they are free of haze and lint.



Always dry the transparent surfaces carefully after cleaning them.



Do not spin the cooling fans using compressed air because they could be damaged.

6. Technical Specifications

Dimensions and Weight

Length	Width	Height	Weight
25.91 in (638 mm)	8.04 in (204 mm)	11.7 in (297 mm)	16.4 lb (7.5 kg)

Note: Dimensions in inches are rounded.

Power

Power Supply Type	Range	Voltage Selection
Switching (internal)	100 to 240 VAC, 50/60 Hz	Auto-ranging
Parameter	120 V, 60 Hz	230 V, 50 Hz
Consumption	147 W	144 W
Operating Current	1.2 A	0.6 A
Power linking current (products)	12 A (9 products)	12 A (18 products)
Fuse	T 2.5 A, 250 V	T 2.5 A, 250 V
Power I/O	U.S./Worldwide	UK/Europe
Power input connector	powerCON compatible	powerCON compatible
Power output connector	powerCON compatible	powerCON compatible
Power cable plug	Edison (U.S.)	Local plug

Light Sources

Effect	Type	Color	Quantity	Power	Current	Lifespan
Moving heads		RGBW	2	80 W total	2.8 A	
Washes	LED	RGBAW+UV	4	40 W total	2.6 A	50,000 hours
LED rings		RGBW	48	10 W total		

Photometrics

Strobe Rate	Moving Head Beam Angle	Wash Beam Angle	Wash Field Angle	Moving Head Illuminance	Wash Illuminance
0 to 20 Hz	5°	20°	37°	24,670 lux per head @ 2 m	525 lux per section @ 2 m

Thermal

Maximum External Temperature	Cooling System
104 °F (40 °C)	Fan-assisted convection

DMX

I/O Connector	Channel Range
3-pin XLR, D-Fi 2.4 GHz	3, 24, or 60

Ordering

Product Name	Item Code	UPC Number
GigBAR Bridge Beam ILS	10052769	781462231170



Contact Us

General Information	Technical Support
Chauvet World Headquarters	
Address: 3360 Davie Rd., Suite 509 Davie, FL 33314 Voice: (954) 577-4455 Fax: (954) 929-5560 Toll Free: (800) 762-1084	Voice: (844) 393-7575 Fax: (954) 756-8015 Email: chauvetcs@chauvetlighting.com Website: www.chauvetdj.com
Chauvet U.K.	
Address: Pod 1 EVO Park Little Oak Drive, Sherwood Park Nottinghamshire, NG15 0EB UK Voice: +44 (0) 1773 511115 Fax: +44 (0) 1773 511110	Email: UKtech@chauvetlighting.eu Website: www.chauvetdj.eu
Chauvet Benelux	
Address: Vaartlaan 9 9800 Deinze Belgium Voice: +32 9 388 93 97	Email: BNLtech@chauvetlighting.eu Website: www.chauvetdj.eu
Chauvet France	
Address: 3, Rue Ampère 91380 Chilly-Mazarin France Voice: +33 1 78 85 33 59	Email: FRtech@chauvetlighting.fr Website: www.chauvetdj.eu
Chauvet Germany	
Address: Bruno-Bürgel-Str. 11 28759 Bremen Germany Voice: +49 421 62 60 20	Email: DEtech@chauvetlighting.de Website: www.chauvetdj.eu
Chauvet Mexico	
Address: Av. de las Partidas 34 - 3B (Entrance by Calle 2) Zona Industrial Lerma Lerma, Edo. de México, CP 52000 Voice: +52 (728) 690-2010	Email: servicio@chauvet.com.mx Website: www.chauvetdj.mx

Warranty & Returns

For warranty terms and conditions and return information, please visit our website.

For customers in the United States and Mexico: www.chauvetlighting.com/warranty-registration.

For customers in the United Kingdom, Republic of Ireland, Belgium, the Netherlands, Luxembourg, France, and Germany: www.chauvetlighting.eu/warranty-registration.